



Werkzeug- und Maschinenhandel Schieder

www.profizone24.at

SCHIEDER Minibagger WE16

Der WE16 wird standardmäßig mit einer **mechanischen Schnellkupplung** ausgeliefert.

Der **Komfortsitz** erleichtert dem Bediener das Arbeiten.

Hydrauliksystemteile renommierter Marken gewährleisten die **stabile Qualität** des Minibaggers.

Einsatzgebiet: Gartenbau, Erdbewegung, kleine Abbrucharbeiten, etc.

CE-Zertifiziert nach EN ISO 12100:2010; EN 60204-1:2018
EN 474-1:2006+A6:2019; EN 474-5:2006+A3:2013

Die Auslieferung erfolgt standardmäßig mit einer 400mm Schaufel.
Schaufelvolumen: 0,045m³

Schaufel-Set inklusive: 200mm Grablöffel, 1.000mm Planierlöffel starr

Technische Details:

Motor: Yanmar 3TNV70-S

3 Zylinder, 10 kW/13 PS

2.200 U/Min.

Betriebsgewicht: 1.600 kg

Geschwindigkeit max.: ca. 3 km/h

Maße Planierschild: (L) 1.120 mm

(B) 240 mm

Kapazität Treibstofftank: 19l

Hydrauliktank: 15.3l

Hydraulikfluss: 23,3l/Min.

max. Steigfähigkeit: ca. 58% (30°)

Grabkraft Schaufel: 10.5 kN

Grabkraft Arm: 6.5 kN

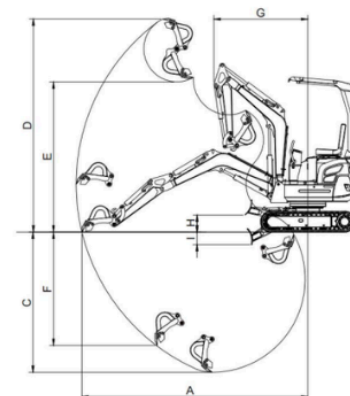
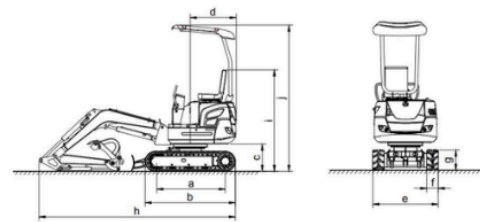

Wheel Thread	1130 mm	a
Total length of track	1450 mm	b
Platform ground clearance	437 mm	c
Platform back turning radius	740 mm	d
Chassis width	1040 mm	e
Track width	180 mm	f
Track height	320 mm	g
Transport length	3180 mm	h
Seal height to the floor	1837 mm	i
Total height	2377 mm	j

OPERATING RANGE		
Max. Digging radius on ground	3470 mm	A
Max. Digging radius	3560 mm	B
Max. Digging depth	2150 mm	C
Max. Digging height	3275 mm	D
Max. Dumping height	2310 mm	E
Max. Vertical digging depth	1740 mm	F
Min. Rotation radius	1440 mm	G
Max. Upgrade height of bulldozer blade	282 mm	H
Max. Digging depth of bulldozer blade	192 mm	I

